

**SCIENCE**

# Internal Grinding Machine

**Hydraulic Series**

**GIS-200SH(L) II**

**Digital control Series**

**GIS-20N**

**GIS-25HE(L) II**

**GIS-200DM(L)**

**GIS-800LE**



Kagaku Keiki Kenkyusho Co.,Ltd.

# Achieving the ultimate precision machining

## Internal Grinding Machine

Manual processing is fundamental to maintaining high precision.

By performing sliding adjustment (scraping), the accuracy of bed and table sliding surface is maintained over a long period of time. Additionally, sliding adjustment is performed on all the other main parts.

High-precision technology realized by Kagaku Keiki Kenkyusho Co.,Ltd. specializing in metal processing



### Processing accuracy

#### 1. Work piece (In-house test piece)

Work piece Measurement/  $\phi 35 \times 30L$   
Material /SCM435  
Hardness/HRC.50 ~ 55

#### 2. Measurement Data

Roundness/0.1  $\mu m$

Magnification 5,000 Times



Magnification 10,000 Times



The above data is actual test result values. Not guaranteed values.

※Same work piece



# Product lineup

## Hydraulic Series

▶ P4~

GIS-200SH II  
GIS-200SHL II



## Digital control Series

▶ P8~

GIS-20N



GIS-25HE II  
GIS-25HEL II



GIS-200DM  
GIS-200DML



GIS-800LE



# Hydraulic Series

## GIS-200SH II GIS-200SHL II

Standard machine with excellent versatility and ease of operation

This unit has been manufactured so that it can easily handle the processing of high-variety low-volume works with high efficiency like works requiring lots of retooling. The grinding cycle is semi-automatic. Based on the GIS-200SH, we also manufacture the GIS-200SHL, which can process longer workpieces by extending the center distance.

※This machine is mounted with special accessories.

※Based on this machine, we are also manufacturing internal grinding machines with complex angle up to 50°.



GIS-200SH • 200SHL  
Operation board  
(Including Special Accessory)



Table manual handle



Infeed manual handle

### Steady rest (Special Accessory)



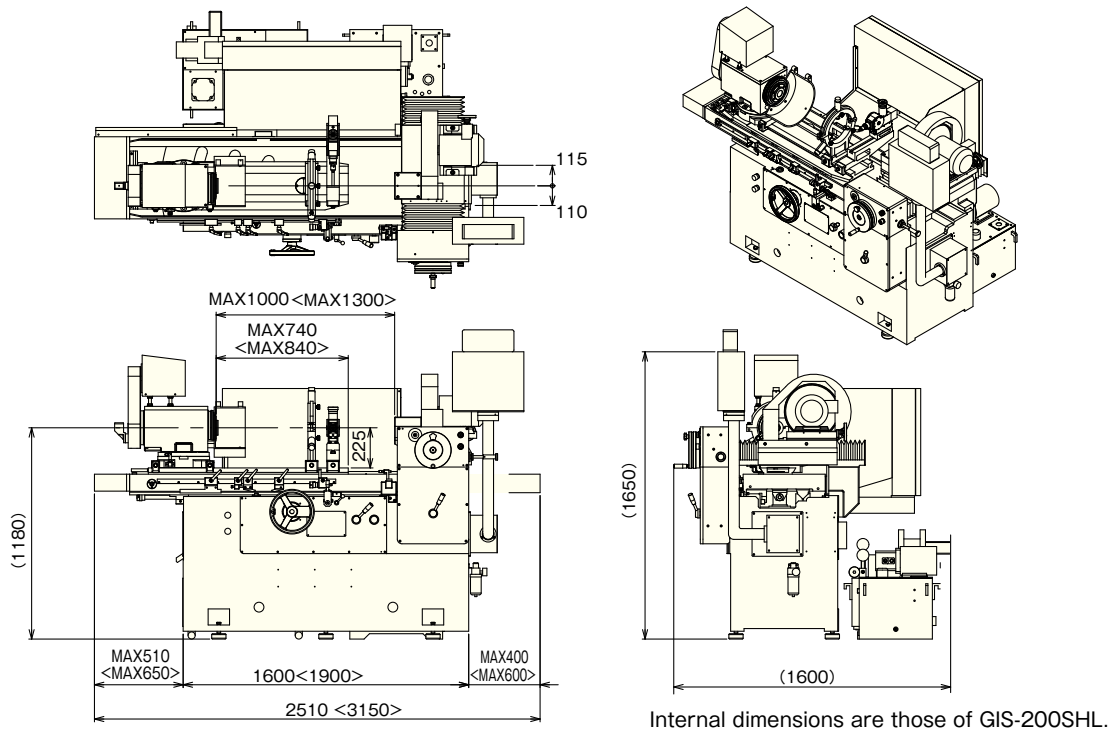
Used for processing long work pieces like spindles etc. By mounting the main spindle head on the same plane as the turntable, positioning, as well as putting on and taking off can be performed easily.

### Scale counter (Special Accessory)



Dimensions can be easily checked for workpieces with steps on the inner surface.

## Layout drawing



## Main specifications

(Due to product improvement, design and specifications of the machine may change without prior notice.) (mm)

Machine specifications		GIS-200SH II	GIS-200SHL II
Grinding work piece	Grinding maximum diameter	φ 200	
	Grinding maximum length	200	
	*1 Center core interval	MAX1,000	MAX1,300
Headstock	Swing over table	450	
	Chuck waterproof cover internal swing	φ 300	
	Turning angle	MAX 9°	
	*2 Complex angle	MAX 30°	
	Number of revolutions	MAX1,000min-1	
	Spindle taper hole	MT#5(Through hole φ 25)	
Cutting Section	Maximum amount of cutting movement	225(+side 115, -side 110)	
	Automatic cutting quantity (Continuous variable intermittent)	MAX 0.03/DIA	
	Total Automatic cutting quantity	MAX 1.0/DIA	
Table Section	Maximum stroke	600	800
	Feed rate	MAX 4,000mm/min	
Electric Motor	For Spindle	0.75KW 4P	
	For Wheel Spindle	2.2KW 2P	
	For Hydraulic pump	0.75KW 4P	
	For cooling water	0.1KW 2P	
Weight		2,700kg	2,900kg

\*1 Distance from the main spindle axis edge, to the grinding wheel spindle housing edge surface.

\*2 The combined angle is the total angle at which the headstock is swirled by 21° .  
(It depends on the length of the workpiece and the inner diameter.)

# Accessories

## Hydraulic Series

### GIS-200SH II

### GIS-200SHL II

## Standard Accessory

		200SH II 200SHL II
1	Parallel dresser equipment	○
2	Hydraulic unit	○
3	Chuck waterproof cover (Inner swing 300 φ)	○
4	Standard tool, leveling pad	○
5	Cooling water tank unit	○
6	Spindle inching equipment	○
7	Front/Back water injection equipment	○
8	Dial gauge mounting bracket for spindle turning	○
9	Grinding Wheel Spindle inverter equipment	○

## Special Accessory

			200SH II 200SHL II
1	Grinding Wheel Spindle	15,000, 20,000, 30,000min-1	○
		8,000, 10,000min-1	○
2	High speed Grinding Wheel Spindle	10 ~ 20,000min-1	○
		15 ~ 30,000min-1	○
3	3-Jaw scroll chuck #7 ~ #10		○
4	Others, oil, pneumatic 4-Jaw chuck		☆
5	Steady rest φ30 ~ φ130, φ50 ~ φ150, φ130 ~ φ200		○
6	Cooling water cleaning equipment	Magnetic (20 l/min)	○
		Paper Filter Type	☆
		With magnet and Paper filter	☆
7	Grinding Wheel Exchange axis		☆
8	Collet-type Grinding Wheel Exchange axis (15,000, 30,000min-1)		○
9	Collet-type Head Various Types		○
10	Collet-type Sleeve Various Types		○

			200SH II 200SHL II
11	Head for heavy work pieces		☆
12	Automatic cycle equipment		○
13	Table left/right fine movement equipment		○
14	Grinding Wheel fine movement equipment		○
15	Table fine movement stopper equipment		○
16	Total Automatic cutting quantity 2mm/DIA 3mm/DIA		○
17	Working Light	AC100V	○
		DC24V	○
18	Hydraulic fluid		○
19	Signal tower		☆
20	Center height 50mm UP		○
21	Hydraulic oil filtration equipment		○
22	Specified color		○
23	Cutting side Linear scale		○
24	Table side Linear scale		○
25	Chuck waterproof cover (Inner swing φ400)		○
26	Chuck waterproof cover (Inner swing φ500)		☆

○Mountable ☆Requires separate arrangement





Grinding Wheel Spindle



3-Jaw scroll chuck



Grinding Wheel Exchange axis



Collet-type Grinding Wheel Exchange axis



Cooling water cleaning equipment



Hydraulic oil filtration equipment



Steady rest



Signal Tower



Working Light AC100V

# Digital control Series

## High Precision Processing using Digital Control

### Easy input with few settings

Since there is no need for special program settings, machining is more efficient and easy for beginners.

### 2-Axis (X · Z) are digital controlled Further high precision processing is realized

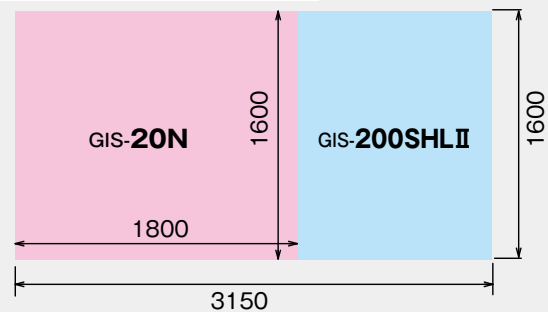
By replacing skilled processing technology with digital technology, high-precision machining can be performed easily and the burden on the operator is reduced.

#### Setup screen (It depends on the model.)



#### Small works should be processed in small machines.

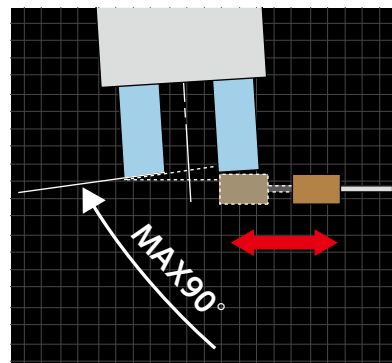
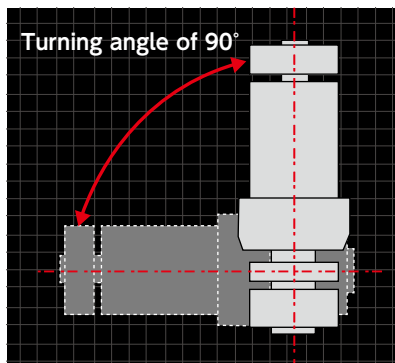
Comparative map of the area required



60% space reduction when compared with the GIS-200SH II

#### For GIS-20N type only

Turning angle of 90° therefore grinding of a wide-angle taper is also possible



Traverse cut grinding is possible without requiring molding of wide-angle taper and Grinding Wheel Turning angle 90° .



# GIS-20N

Up to inner diameter Ø50 small-diameter flange work dedicated machine

## Compact and Space saving is realized

This machine is a space saving, fully automatic internal grinding machine that was manufactured for the purpose of efficiently processing small diameter works.

※ This machine is mounted with special accessories.

## Even with a small size, high rigidity and high accuracy grinding is realized

This machine's cutting drive section has the same level of specifications as the high-performance GIS-25HE. It is small but high rigidity machine.

※ Grinding Wheel spindle is also compatible with the GIS series and exchange is possible.



Sub-operation panel

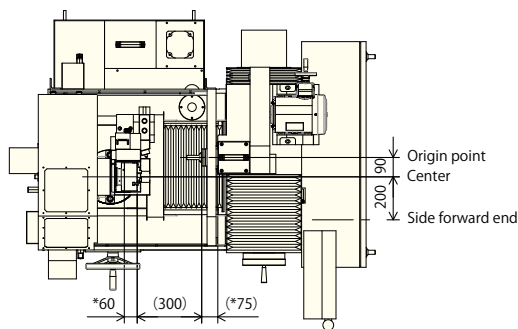


Table manual handle

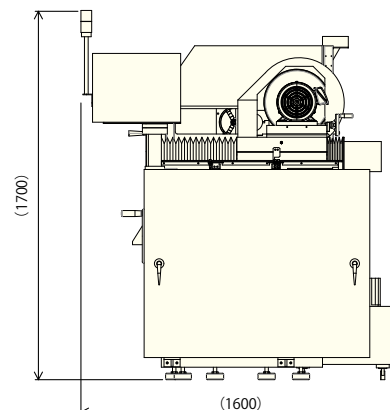
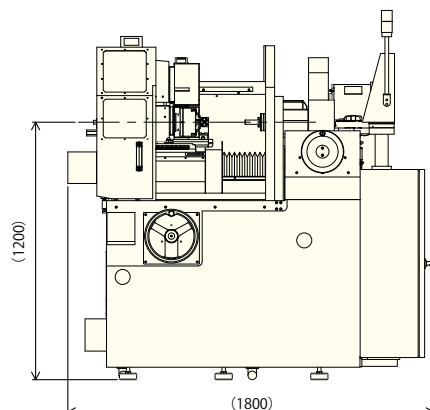
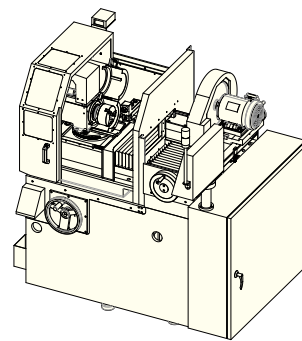


Infeed manual handle

## Layout drawing



(\*75) is the length from the grinding wheel housing to the front end of the grinding wheel spindle at 15,000 rotations.  
\*60 is #5 chuck width



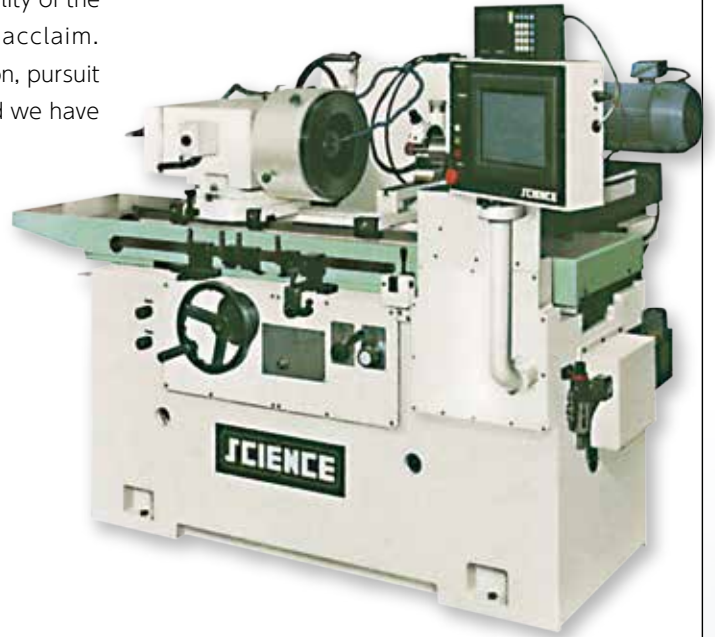
# Digital control Series

## GIS-25HE II GIS-25HEL II

From high-mix, low-volume production to mass production

This machine maintains the processing precision and workability of the GIS-200SH for which we have hither to received wide acclaim. Through digital control of various cycles in the Cutting Section, pursuit of high-precision machining has becomes more possible, and we have further improved reliability.

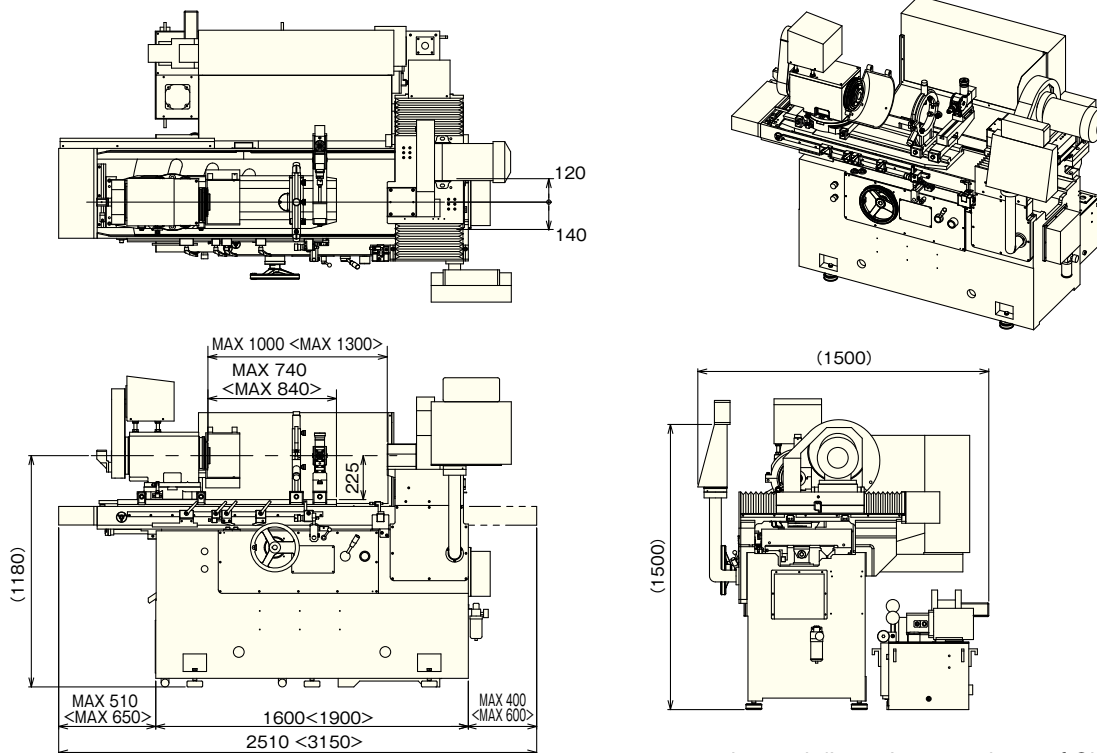
※ This machine is mounted with special accessories.



Setup screen (It depends on the model.)



Layout drawing



Internal dimensions are those of GIS-25HELI

# GIS-200DM GIS-200DML

Stable, high-precision grinding realized by 2-axis digital control

This grinder maintains the same shape as the GIS-200SH model, and features 2-axis digital control and a manual handle for high-precision grinding and ease of use.



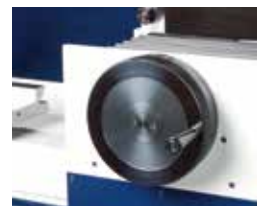
Control panel (touch panel)



Sub-operation panel

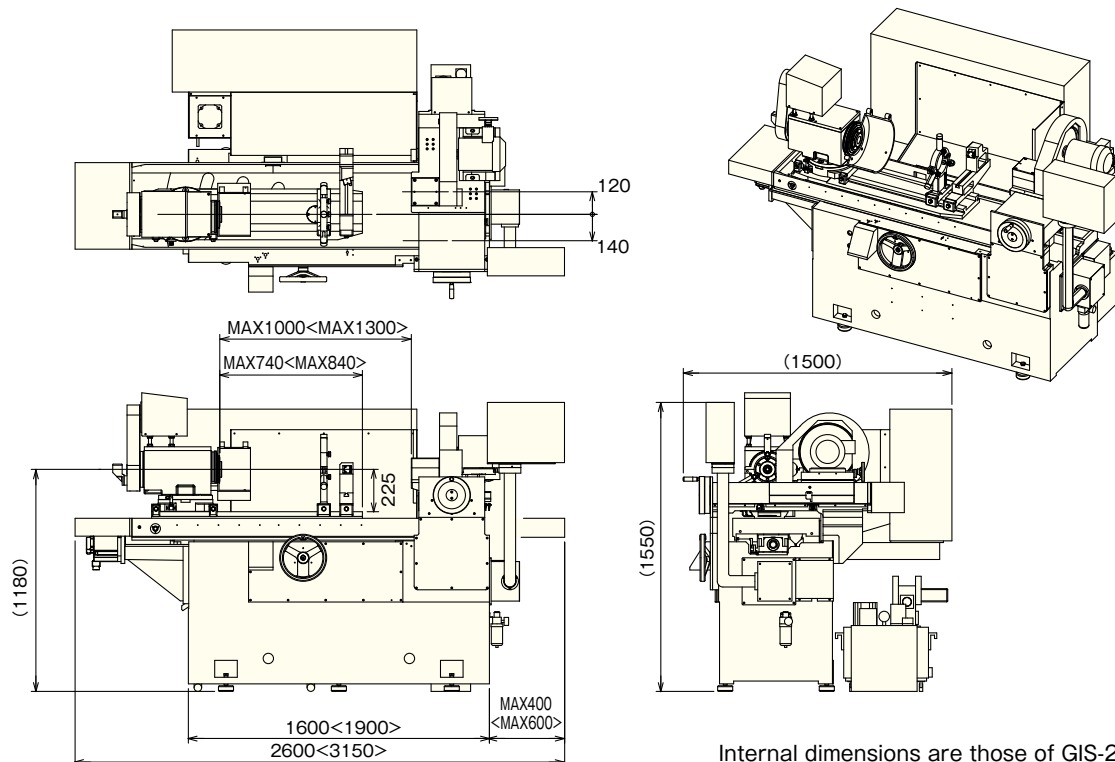


Table manual handle



Infeed manual handle

## Layout drawing



Internal dimensions are those of GIS-200DML.



# Digital control Series

## GIS-800LE

Free selection from Spindle work pieces to Flange work pieces

By moving the work head and increasing the distance between center, it is possible to process from flange work pieces to spindle work pieces freely.



### Steady rest



**Installation is easy and setup time is reduced**

By mounting the main spindle head on the same plane as the turntable positioning, as well as putting on and taking off can be performed easily.

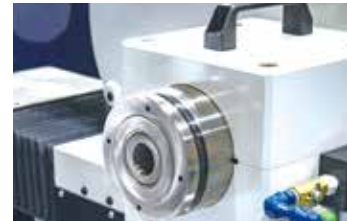
### ANGLE



**An encoder is mounted and angles digitize**

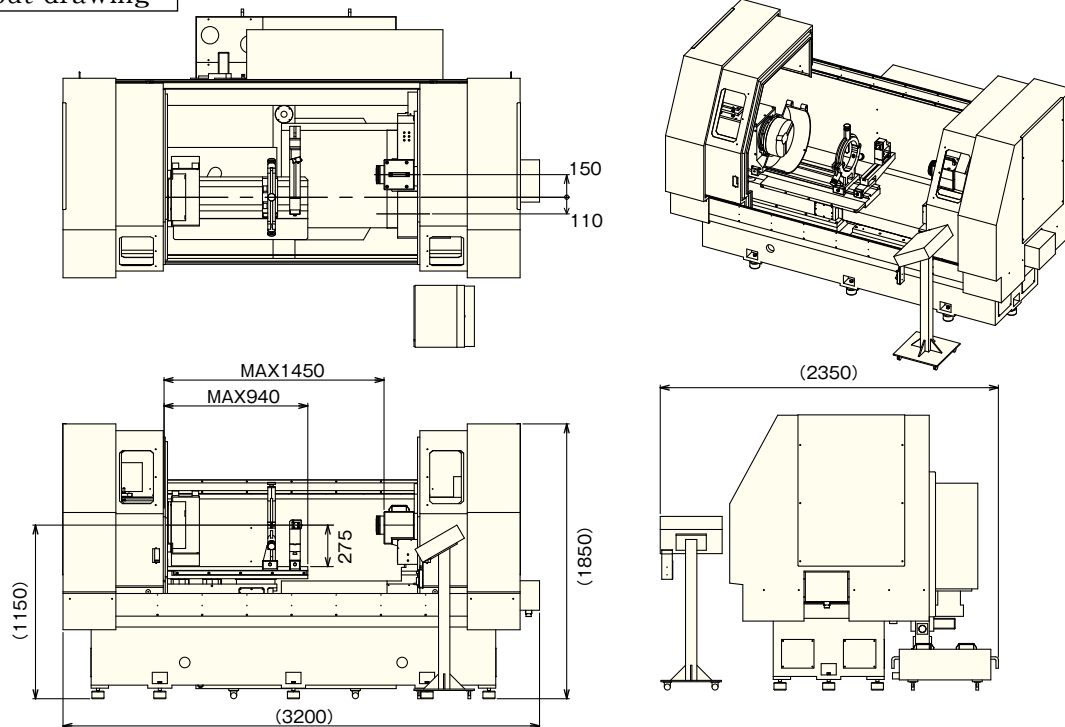
Angle setting is facilitated by the encoder, and a high precision taper grinding is possible without requiring high degree or proficiency.

### High rigidity grinding wheel spindle



The body diameter is  $\phi 120$ , which is thicker and more rigid than other models ( $\phi 80$ ).

### Layout drawing



## Main specifications

GIS-20N, GIS-25HE II, GIS-25HEL II, GIS-200DM, GIS-200DML, GIS-800LE

(Due to product improvement, design and specifications of the machine may change without prior notice.) (mm)

Machine specifications		GIS-20N	GIS-25HE II GIS-25HEL II	GIS-200DM GIS-200DML	GIS-800LE
Grinding work piece	Grinding maximum diameter	φ50	φ200		
	Grinding maximum length	50	200		
	*1 Center core interval	MAX467	MAX1,000(1,300)		MAX 1,450
Headstock	Swing over table	-	450		550
	Chuck waterproof cover internal swing	φ200	φ300		-
	Turning angle	MAX 90°	MAX 9°		MAX 10°
	*2 Complex angle	-	MAX 30°		-
	The Number of revolutions	MAX1,000mim-1			MAX 700mim-1
	Spindle taper hole	MT#4 (Through hole φ20)	MT#5(Through hole φ25)		φ67-450L (Through hole φ47)
Cutting Section	Maximum amount of cutting movement	290 (+side90, -side200)	260(+side120, -side140)		260 (+side 150, -side110)
	Least input increment	0.0001	0.001	0.0001	
	Total Automatic cutting quantity	MAX 25	MAX 100		
	Cutting-in position	Table - Left, Right, Both Ends, Continuous (Select)			
	Manual mode	Step, Jog, Handle (Select)	Step, Jog, Pulse handle (Select)	Step, Jog, Handle (Select)	Step, Jog, Pulse handle (Select)
	Feed rate	MAX 15mm/s	MAX 20mm/s	MAX 50mm/s	MAX 60mm/s
	Table section	Maximum stroke	250	600(800)	
Feed rate		MAX 900mm/min	MAX 4,000mm/min		MAX 3,600mm/min
Least input increment		0.0001	-	0.0001	
Manual mode		Jog, Handle (Select)	-	Jog, Handle (Select)	Step, Jog, Pulse handle (Select)
Electric Motor	For Spindle	0.4KW 4P	0.75KW 4P		2.2KW 4P
	For Wheel Spindle	2.2KW 2P			3.7KW 2P
	For Hydraulic pump	-	0.75KW 4P	-	-
	For cooling water	0.1KW 2P			
	For Cutting Section Drive	0.75kW servo motor			
	For Table section Drive	0.75kW servo motor	-	3kW servo motor	
Weight		1,200kg	2,700kg(2,900kg)		5,000kg

\*1 The distance from the spindle shaft end to the end face of the grinding wheel spindle housing.

\*2 The combined angle is the total angle at which the headstock is swirled by 21° .

(It depends on the length of the workpiece and the inner diameter.)

# Accessories

## Digital control Series

**GIS-20N**

**GIS-25HE II**

**GIS-25HEL II**

**GIS-200DM**

**GIS-200DML**

**GIS-800LE**



Grinding Wheel Spindle



3-Jaw scroll chuck



Grinding Wheel Exchange axis



Collet-type Grinding Wheel Exchange axis



Steady rest



Cooling water cleaning equipment



Hydraulic oil filtration equipment



Signal Tower



Working Light AC100V

## Standard Accessory

		20N	25HEII 25HELI	200DM 200DML	800LE
1	Parallel dresser equipment	☆	○	○	○
2	Hydraulic unit	×	○	×	×
3	Chuck waterproof cover (Inner swing $\phi$ 300)	×	○	○	×
4	Chuck waterproof cover (Inner swing $\phi$ 200)	○	×	×	×
5	Standard tool, leveling pad	○	○	○	○
6	Cooling water tank unit	○	○	○	○
7	Spindle inching equipment	○	○	○	○
8	Front/Back water injection equipment	○	○	○	○
9	Dial gauge mounting bracket for spindle turning	×	○	○	○
10	Sliding cover	×	×	×	○
11	Grinding Wheel Spindle inverter equipment	○	○	○	○



## Special Accessory

			20N	25HEII 25HELI	200DM 200DML	800LE
1	Grinding Wheel spindle φ80 series	15,000, 20,000, 30,000min-1	○	○	○	×
		8,000, 10,000min-1	☆	○	○	×
2	High speed Grinding Wheel φ80 series	10 ~ 20,000min-1	☆	○	○	×
		15 ~ 30,000min-1	○	○	○	×
3	Grinding Wheel spindle φ120 series	8,000min-1	×	×	×	○
		15,000min-1	×	×	×	○
4	3-Jaw scroll chuck #7 ~ #10		×	○	○	☆
5	3-Jaw scroll chuck #3 ~ #5		○	×	×	×
6	Others, oil, pneumatic 4-Claw chuck		☆	☆	☆	☆
7	Steady rest φ30 ~ φ130, φ50 ~ φ150, φ130 ~ φ200		×	○	○	○
8	Cooling water cleaning equipment	Magnetic	○	○	○	○
		Paper Filter Type	☆	☆	☆	☆
		With magnet and Paper filter	☆	☆	☆	☆
9	Grinding Wheel Exchange axis		☆	☆	☆	☆
10	Collet-type Grinding Wheel Exchange axis (15,000, 30,000min-1)		○	○	○	☆
11	Collet-type Head Various Types		○	○	○	☆
12	Collet-type Sleeve Various Types		○	○	○	☆
13	Head for heavy work pieces		×	☆	☆	×
14	Table left/right fine movement equipment		×	○	×	×
15	Table fine movement stopper equipment		×	○	×	×
16	Working Light	AC100V	○	○	○	○
		DC24V	○	○	○	○
17	Hydraulic fluid		×	○	×	×
18	Signal tower		○	○	○	○
19	Automatic power cutoff equipment		○	○	○	○
20	Pulse handle		○	○	×	Standard
21	Center height 50mm UP		×	○	○	×
22	Hydraulic oil filtration equipment		×	○	×	×
23	Specified color		○	○	○	○
24	Table side Linear scale		×	○	×	×
25	Sliding cover		○	×	☆	Standard
26	Turning angle indicator		Standard	×	×	Standard
27	Chuck waterproof cover(Inner swing φ400)		×	○	○	×
28	Chuck waterproof cover (Inner swing φ500)		×	☆	☆	☆
29	Mist collector		○	×	×	○
30	Cleaning gun		○	○	○	○

○ Mountable × Not Mountable ☆ Requires separate arrangement

**SCIENCE**

**Kagaku Keiki Kenkyusho Co.,Ltd.**

**Head office · Factory**

1-2-20 Higashitakami, Nagaoka shi, Niigata, 940-0006 JAPAN  
TEL: +81-258-24-0646 FAX: +81-258-24-5681

**<https://kagakukeiki.co.jp>**

